

# Installation & Operation Manual

XX164-00

## MODEL VF-100 AND VF-30 SINGLE-CHANNEL FIBER-OPTIC VIDEO TRANSMISSION SYSTEM



Copyright © 2007 Vicon Industries Inc. All rights reserved.  
Product specifications subject to change without notice.  
Vicon and its logo are registered trademarks of Vicon Industries Inc.

**VICON INDUSTRIES INC., 89 ARKAY DRIVE, HAUPPAUGE, NEW YORK 11788**  
**TEL: 631-952-CCTV (2288) FAX: 631-951-CCTV (2288) TOLL FREE: 800-645-9116**  
**24-Hour Technical Support: 800-34-VICON (800-348-4266)**  
**UK: 44/(0) 1489-566300 WEB: [www.vicon-cctv.com](http://www.vicon-cctv.com)**







Dear Valued Customer:

Thank you for selecting Vicon systems and products for your video needs.

Since Vicon's beginning in 1967, our only business has been the design, engineering, and production of the highest quality video systems and equipment for use in a wide variety of security, safety, control, surveillance, and communication applications.

We stand behind the quality and dependability of every product with an industry leading Beneficial Use warranty.

If you are not satisfied with a Vicon product or service, I would like to know. Your complete satisfaction is the mission of every Vicon employee.

Sincerely,

A handwritten signature in black ink, appearing to read "Kenneth M. Darby". The signature is fluid and cursive, with a long horizontal stroke extending to the right.

Kenneth M. Darby  
President



## FCC Notice

*Note: Complies with Federal Communications Commission Rules & Regulations Part 15, Subpart B for a Class A digital device.*

### WARNING

This equipment generates and uses radio frequency energy and if not installed and used properly, that is, in strict accordance with the manufacturer's instruction, may cause interference to radio and television reception. It has been type tested and found to comply with the limits for a Class A computing device in accordance with the specification in subpart B of part 15 of the FCC rules, which are designed to provide reasonable protection against such interference in a commercial installation. However, there is no guarantee that interference will not occur in a particular installation. If this equipment does cause interference to radio and television reception, which can be determined by turning equipment off and on, the user is encouraged to try and correct the interference by one or more of the following measures:

- Reorient the receiving antenna.
- Relocate the equipment with respect to the receiver.
- Relocate the equipment away from the receiver.
- Plug the equipment into a different electrical outlet so that the equipment and receiver are on different branch circuits.

If necessary, the user should consult the dealer or an experienced radio/television technician for additional suggestions.

The user may find the following booklet prepared by the Federal Communications Commission helpful:

“Interference Handbook, Bulletin CIB-2”

This booklet is available from the U.S. Government Printing Office, Superintendent of Documents, Mailstop SSOP, Washington, D.C. 20402-9328, ISBN 0-16-045542-1.

**Warning:** Power must be removed from this unit before removing circuit modules or ribbon cables.

**Caution:** This unit contains circuit cards with integrated circuit devices that can be damaged by static discharge. Take all necessary precautions to prevent static discharge

# Important Safeguards

## GRAPHIC SYMBOL EXPLANATION

The lightning bolt symbol alerts the user to the presence of dangerous voltage that may present the risk of electric shock.

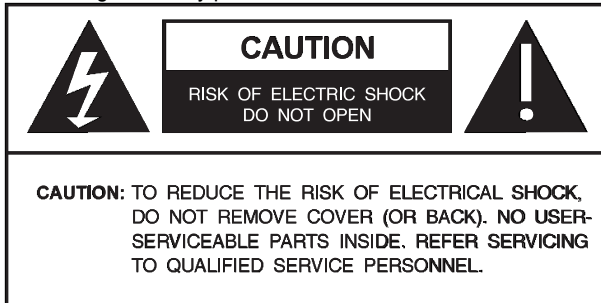

The exclamation point symbol alerts the user to the presence of important operating and maintenance instructions.

1. **Read Instructions** - Read all safety and operating instructions before the product is operated.
2. **Retain Instructions** - Retain all safety and operating instructions for future reference.
3. **Heed Warnings** - Pay attention to all product warnings.
4. **Follow Instructions** - Follow all operating instructions.
5. **Cleaning -(Do not use caustic, abrasive or aerosol cleaners)**
  - a) For units that CAN BE DISCONNECTED from the power source, use a damp cloth for cleaning.
  - b) For units that CANNOT BE DISCONNECTED from the power source, use a damp cloth for cleaning and do not allow moisture or liquids to enter vents.
6. **Attachments** - Use only UL Listed Vicon recommended attachments to prevent unit damage and personal injury.
7. **Water and Moisture** - Use only products designed for outdoor environments where they will be exposed to water or moisture.
8. **Accessories** - Do not place the unit on an unstable surface to avoid falling. Use only UL Listed Vicon recommended mounting accessories.
9. **Ventilation** - Do not block ventilating slots and openings as they ensure reliable operation. Do not place the unit near a heat source or into an enclosure unless recommended by Vicon.
10. **Power Sources** - The product should only be operated from the recommended power source. Use only a UL Class 2 indoor/dry or Class 3 outdoor/wet power supply.
11. **Grounding** - Only products equipped with a 3-prong grounded plug should be inserted into a grounded power outlet. Contact an electrician to replace an obsolete outlet. Do not force a plug into a non-grounded outlet.
12. **Power Cord Protection** - Power supply cords should not be routed in trafficked areas or in tight spaces where they will be

pinched or used to bear weight. Allow some slack in the cord where it enters the unit.

13. **Outdoor Cable Grounding** - Use only grounded outdoor cables to protect against voltage surges and static charges. Section 810 of the National Electrical Code, ANSI/NFPA 70-1984, provides information on proper grounding of the lead-in wire to an antenna discharge unit, size of grounding conductors and the requirements of grounding electrodes.
14. **Lightning** - Disconnect the product from its power source and cable system when possible to prevent damage due to lightning and power-line surges.
15. **Power Lines** - Do not locate outside cables over power or utility lines where they can fall and make direct contact. Contact with power lines can be fatal.
16. **Overloading** - Do not overload wall outlets and extension cords to prevent risk of fire and electric shock.
17. **Object and Liquid Entry** - Never probe through, or spill liquid into, enclosure openings to prevent risk of fire or electric shock.
18. **Servicing** - Refer all servicing to qualified service personnel.
19. **Damage Requiring Service** - Obtain service when:
  - a) The power-supply cord or plug is damaged.
  - b) Objects have fallen or liquid has been spilled into the product.
  - c) The product is not designed for outdoor use and has been exposed to water or moisture.
  - d) The product does not operate per the operating instructions. Perform Vicon recommended adjustments, modifications and troubleshooting only to avoid unit damage and personal injury.
  - e) The product has been dropped.
  - f) The product shows a significant change in performance.
20. **Replacement Parts** - Use only Vicon specified replacement parts or an approved equivalent to prevent unit damage and injury.
21. **Safety Check** - Request safety checks to be performed following repair or maintenance to verify proper operation.
22. **ESD Precaution** - Take all normal electrostatic discharge precautions to avoid component damage during installation and operation.
23. **For 230 VAC Devices Only** - When the disconnect device is not incorporated in the equipment or when the plug on the power supply is intended to serve as the disconnect device, follow the guidelines below:
  - a) For permanently connected 230 VAC units, a readily accessible disconnect device must be incorporated into the site wiring.
  - b) For 230 VAC units with a plug, the outlet must be installed near the unit and be easily accessible.

## **Introduction**

The information in this manual covers the installation of the VF-100 and VF-30RR Fiber-Optic Video Transmission System. This system should only be installed by a qualified technician using approved materials and wiring practices in accordance with the National Electrical Code ANSI/NFPA 70, state, and local electrical codes. Read these instructions thoroughly before beginning an installation.

## **Functional Description**

The VF-100 system operates as a transmitter/receiver pair for the transmission of baseband NTSC, PAL, RS170, or RS343 video signals over a single multimode fiber optic cable. The standalone transmitter is Model VF-100T; the rack-mount version is VF-100TR. The standalone receiver is model VF-100R; the rack-mount version is model VF-100RR. The VF-30RR receiver contains the electronics and optics of three VF-100RR units mounted on one printed circuit board to save space and reduce cost.

The VF-100 system converts a single video input into a single FM modulated optical output using an 850 nm wavelength source. It is designed to operate over an optical loss budget range of 0 to 12 dB with a maximum distance of up to 2.5 km. The system operates on 50 um or 62.5 um multimode fiber.

The standalone modular units are contained in compact and rugged aluminum housing with internal DC voltage regulation. The detachable terminal block and LED indicators provide for easy installation and monitoring of video and DC power. The rack-mount units are designed for rack mounting in the VF-SR-20/2 card cage. Slide in rack mounting and a LED indicator provide for easy installation and monitoring of video and power.



# Installation

## Standalone Modules

Mount the unit to a secure surface using #8 (3 mm) hardware in four places. See the figure that follows for mounting dimensions. Be sure to allow sufficient room for the required minimum bend radius of the fiber cable used.

## Rack-Mount Cards

The unit slides into any open slot in the VF-SR-20/2 card cage. Use a small screwdriver to push and lock the two ¼-turn fasteners into place. Please note that when installing this card in the position directly next to the power supply in the card cage, it may be necessary to make the signal connections at the rear of the card before fully seating the card into its slot.

## Power Source

*Note: This product (standalone unit) should be powered by a listed Class 2 power supply only.*

The standalone unit requires a +12 VDC power source for proper operation. The DC input is diode protected. Current draw is approximately 100 mA maximum. An appropriate power supply is included with these units. The negative side of the power input is directly connected to ground. ANSI/NFPA 70 Class 2 wiring is recommended.

For the rack-mount models, power is supplied by the card cage. Please refer to the VF-SR-20/2 and VF-PSR-2 instruction manual XX164-60 for further details.

## Power Connection

On standalone units, power is supplied to the unit via a two-pin terminal connector. Follow label on unit for proper orientation of +12 volt DC and ground.

For rack-mount units, power is supplied to the unit via a four-finger backplane connector. The VF-100RR and VF-30RR can be inserted into the card cage or removed from the card cage with power applied to the backplane.

## Input/Output Connections

The fiber optic connection is made via a ST connector located on the right side of the unit. Be sure to allow sufficient room for the required minimum bend radius of the fiber cable used.

The video input connection is made via a BNC connector on the unit (left side of the standalone module/back of the rack unit). The video input should be connected to an appropriate 75Ω baseband video source such as a camera or a video recorder output. For optimum performance, the video cables should be the shortest length of coax practical.

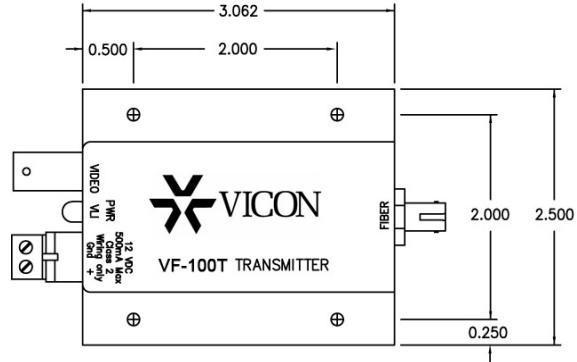
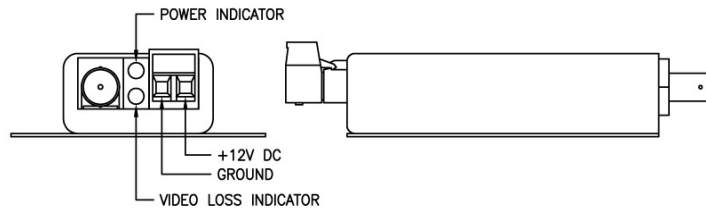

VLI: VIDEO LEVEL INDICATOR  
 - INDICATORS ARE GREEN WHEN PROPER LEVELS ARE PRESENT. THEY ARE RED WHEN SIGNALS ARE MISSING OR AT INCORRECT LEVELS.

### Standalone Module VF-100T

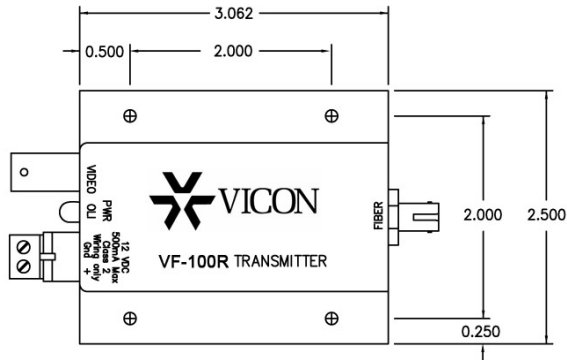
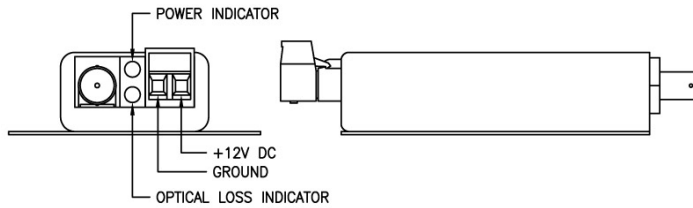

OLI: OPTICAL LEVEL INDICATOR  
 - INDICATORS ARE GREEN WHEN PROPER LEVELS ARE PRESENT. THEY ARE RED WHEN SIGNALS ARE MISSING OR AT INCORRECT LEVELS.

### Standalone Module VF-100R

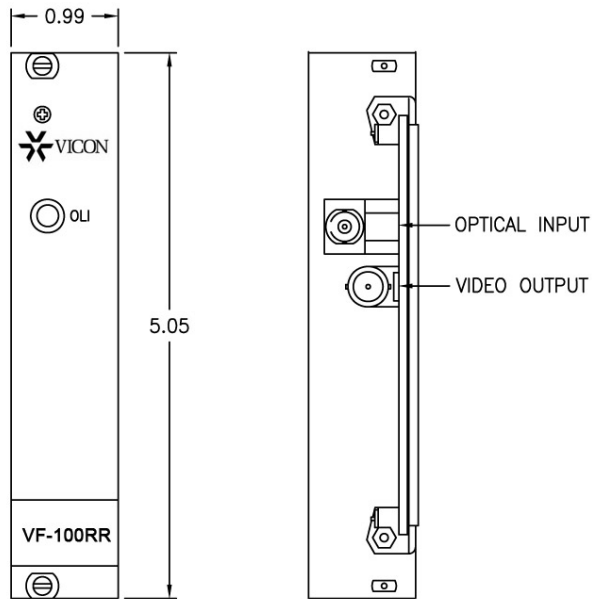

OLI: OPTICAL LEVEL INDICATOR  
 - INDICATORS ARE GREEN WHEN PROPER LEVELS ARE PRESENT. THEY ARE RED WHEN SIGNALS ARE MISSING OR AT INCORRECT LEVELS.

### Rack-Mount Unit VF-100RR

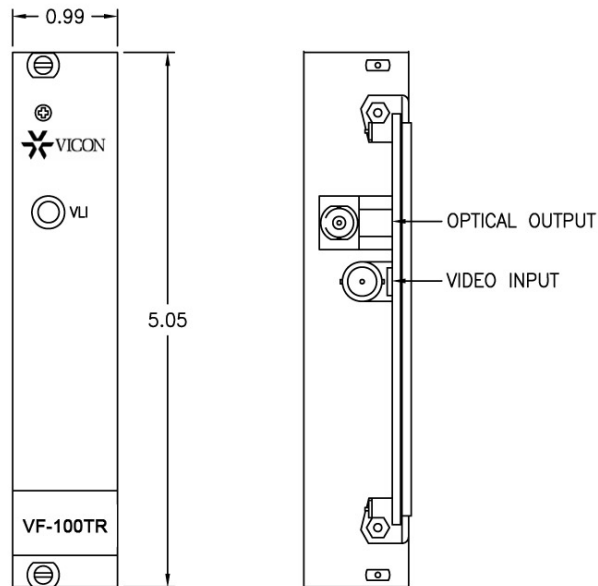

VLI: VIDEO LEVEL INDICATOR  
 - INDICATORS ARE GREEN WHEN PROPER LEVELS ARE PRESENT. THEY ARE RED WHEN SIGNALS ARE MISSING OR AT INCORRECT LEVELS.

### Rack-Mount Unit VF-100TR

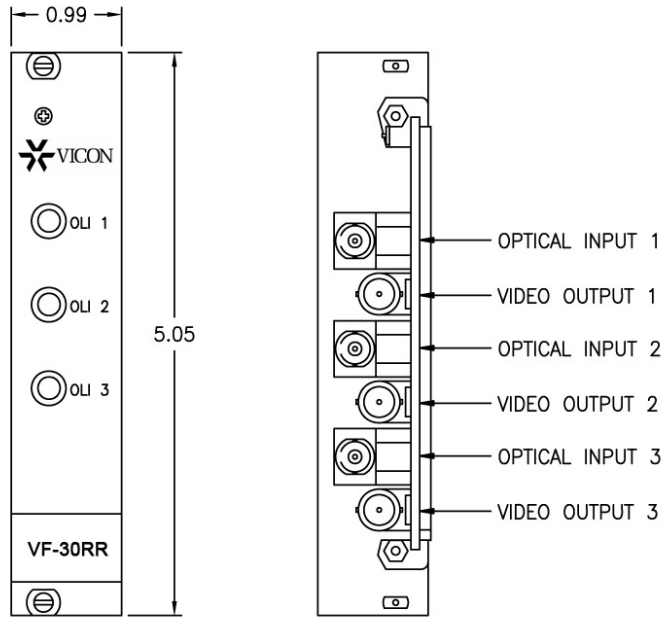

OLI: OPTICAL LEVEL INDICATOR  
 - INDICATORS ARE GREEN WHEN PROPER LEVELS ARE PRESENT. THEY ARE RED WHEN SIGNALS ARE MISSING OR AT INCORRECT LEVELS.

**Rack-Mount Unit VF-30RR**

## Status Indicators Standalone Units

The VF-100T transmitter and VF-100R receiver provide the following LED status indicators to aid in installation and troubleshooting:

### Power

A green LED indicator monitors the internal DC voltage created within the unit. Power status associated with this LED is summarized below.

Power Indicator	Power Status
Green	Voltage Present
Off	Voltage Not Present

### VLI and OLI

A green LED indicator is provided for the video input to the VF-100T. Video status associated with this LED is summarized below.

Video Level Indicator	Video Status
Green	Proper Input Video Present
Off	Input Video Not Detected

On the VF-100R, a green LED indicator monitors the power of the optical signal that is being received at from the transmitter. Optical input status is associated with this LED is summarized below:

Optical Level Indicator	Optical Status
Green	Proper Optical Input Power Present
Off	Optical Input Not Detected

## Status Indicators Rack-Mount Units

The VF-100TR transmitter and VF-100RR and VF-30RR receivers provide the following LED status indicator to aid in installation and troubleshooting:

### OLI – VF-100RR and VF-30RR

A bi-color LED indicator monitors the power of the optical signal that is being received at the unit from the transmitter. DC power and optical input status associated with this LED is summarized below.

Optical Level Indicator	DC Power Status	Optical Status
Green	On	Proper Optical Input Power Present
Red	On	Optical Input Not Detected
Off	Off	Check Power Supply

### VLI – VF-100TR

A bi-color LED indicator is provided for the video input to the receiver. DC power and video status associated with this LED is summarized below.

Video Presence LED	DC Power Status	Video Status
Green	On	Proper Input Video Present
Red	On	Input Video Not Detected
Off	Off	Check Power Supply

## Shipping Instructions

Use the following procedure when returning a unit to the factory:

1. Call or write Vicon for a Return Authorization (R.A.) at one of the locations listed below. Record the name of the Vicon employee who issued the R.A.

Vicon Industries Inc.  
89 Arkay Drive  
Hauppauge, NY 11788  
Phone: 631-952-CCTV (2288); Toll-Free: 1-800-645-9116; Fax: 631-951-CCTV (2288)

For service or returns from countries in Europe, contact:

Vicon Industries Ltd  
Brunel Way  
Fareham, PO15 5TX  
United Kingdom  
Phone: +44 (0) 1489 566300; Fax: +44 (0) 1489 566322

2. Attach a sheet of paper to the unit with the following information:
  - a. Name and address of the company returning the unit
  - b. Name of the Vicon employee who issued the R.A.
  - c. R. A. number
  - d. Brief description of the installation
  - e. Complete description of the problem and circumstances under which it occurs
  - f. Unit's original date of purchase, if still under warranty
3. Pack the unit carefully. Use the original shipping carton or its equivalent for maximum protection.
4. Mark the R.A. number on the outside of the carton on the shipping label.

# TECHNICAL INFORMATION

## ELECTRICAL

**Power Requirements:** Standalone: 12 VDC.  
Rack Mount: power supplied from card cage.

**Current:** See Table 1.

**Power Consumption:** See Table 1.

**Heat Equivalent:** See Table 1.

**Radio Emission Standard:** FCC Class A.

## VIDEO

**Number of Channels:** VF100 Series: 1.  
VF30RR: 3.

**Modulation Type:** Frequency Modulation (FM).

**Formats Supported:** NTSC and PAL

**Video Bandwidth:** 8 MHz.

**Horizontal Video Resolution:** 640 TV lines.

**Video Input/Output Impedance:** 75 ohms.

**Video Input Signal:** 1 V p-p nominal, composite video.

**Video Output Signal:** 1 V p-p.

**Differential Phase:** 5°.

**Differential Gain:** 5%.

**Signal-to-Noise Ratio:** 60 dB.

**Interconnection Distance (recommended):** 100 ft (30 m) (video equipment to transmitter or receiver).

**Recommended Cable Type:** RG59/U coaxial cable (Belden no. 9259 or equivalent).

## OPTICAL

**Optical Wavelength:** 850 nm.

**Maximum Optical Attenuation (Loss Budget):** 12 dB (62.5).

**Fiber Type:** 50 or 62.5  $\mu$ .

**Maximum Transmission Distance:** 1.6 m (2.5 km).

## CONNECTORS AND INDICATORS

**Power:** Standalone: 2-pin screw terminal.  
Rack Mount: connector in rack.

**Video:** BNC.

**Optical:** ST type.

**Diagnostics Indicators:** Video, power and optical presence bi-color/green LEDs.

## MECHANICAL

**Dimensions:** Standalone  
Height: 0.8 in. (20 mm).  
Width: 3 in. (76 mm).  
Depth: 2 in. (51 mm).  
Rack Mount: 1 slot.

**Weight:** See Table 2.

**Construction:** Aluminum.

**Finish:** Standalone: Blue.  
Rack mount: Black paint.

**Mounting:** No. 8 (3 mm) hardware, 4 places.

**Shipping Dimensions:** See Table 2.

**Shipping Weight:** See Table 2.

**Shipping Volume:** See Table 2.

## ENVIRONMENTAL

**Operating Temperature Range:** -40 to 165° F (-40 to 74° C), noncondensing.

**Humidity Range:** Up to 95%, relative.

**Storage Temperature Range:** -40 to 185° F (-40 to 85° C)

**Table 1  
Electrical Information**

<b>Model Number</b>	<b>Current (mA)</b>	<b>Power Consumption (W)</b>	<b>Heat Equivalent* [btu/min (cal/min)]</b>
VF-100T	100	1.2	0.068 (0.017)
VF-100TR	180	2.7	0.154 (0.039)
VF-100R	90	1.1	0.062 (0.016)
VF-100RR	140	2.1	0.120 (0.030)
VF-30RR	270	4.1	0.231 (0.059)

\*Note: These figures represent the conversion of 100% of the electrical energy to heat. Actual percentage of the heat generated will be less and will vary from product to product. These figures are provided as an aid in determining the extent of cooling required for an installation.

**Table 2  
Weight and Shipping Information**

<b>Model Number</b>	<b>Weight (lb/kg)</b>	<b>Shipping Dimensions H x W x L (in./mm)</b>	<b>Shipping Weight (lb/kg)</b>	<b>Shipping Volume (ft<sup>3</sup>/m<sup>3</sup>)</b>
VF-100T	0.3/0.14	1.2 x 6 x 10.5 (30 x 152 x 268)	1.3/0.6	0.044/0.0012
VF-100TR	0.45/0.2	1.2 x 6 x 8.8 (30 x 152 x 223)	0.6/0.3	0.37/0.01
VF-100R	0.3/0.14	3.1 x 6 x 10.5 (79 x 152 x 268)	1.3/0.6	0.11/0.003
VF-100RR	0.45/0.2	1.2 x 6 x 8.8 (30 x 152 x 223)	0.6/0.3	0.37/0.01
VF-30RR	0.5/0.23	1.2 x 6 x 8.8 (30 x 152 x 223)	0.7/0.3	0.37/0.01

## Vicon Standard Equipment Warranty

Vicon Industries Inc. (the "Company") warrants your equipment to be free from defects in material and workmanship under Normal Use from the date of original retail purchase for a period of three years, with the following exceptions:

1. VCRs, all models: Labor and video heads warranted for 120 days from date of original retail purchase. All other parts warranted for one year from date of original retail purchase.
2. Video monitor CRT (cathode ray tube) and LCD monitors, all models: One year from date of original retail purchase.
3. Uninterruptible Power Supplies: Two years from date of original retail purchase.
4. VDR-204 and VDR-208 Recorder Series: One year from date of original retail purchase.
5. Normal Use excludes prolonged use of lens and pan-and-tilt motors, gear heads, and gears due to continuous use of "autopan" or "tour" modes of operation. Such continuous operation is outside the scope of this warranty.

Date of retail purchase is the date original end-user takes possession of the equipment, or, at the sole discretion of the Company, the date the equipment first becomes operational by the original end-user.

The sole remedy under this Warranty is that defective equipment be repaired or (at the Company's option) replaced, at Company repair centers, provided the equipment has been authorized for return by the Company, and the return shipment is prepaid in accordance with policy.

The Company will not be obligated to repair or replace equipment showing abuse or damage, or to parts which in the judgment of the Company are not defective, or any equipment which may have been tampered with, altered, misused, or been subject to unauthorized repair.

**Software supplied either separately or in hardware is furnished on an "As Is" basis. Vicon does not warrant that such software shall be error (bug) free. Software support via telephone, if provided at no cost, may be discontinued at any time without notice at Vicon's sole discretion. Vicon reserves the right to make changes to its software in any of its products at any time and without notice.**

**This Warranty is in lieu of all other conditions and warranties express or implied as to the Goods, including any warranty of merchantability or fitness and the remedy specified in this Warranty is in lieu of all other remedies available to the Purchaser.**

No one is authorized to assume any liability on behalf of the Company, or impose any obligations on it in connection with the sale of any Goods, other than that which is specified above. In no event will the Company be liable for indirect, special, incidental, consequential, or other damages, whether arising from interrupted equipment operation, loss of data, replacement of equipment or software, costs or repairs undertaken by the Purchaser, or other causes.

This warranty applies to all sales made by the Company or its dealers and shall be governed by the laws of New York State without regard to its conflict of laws principles. This Warranty shall be enforceable against the Company only in the courts located in the State of New York.

The form of this Warranty is effective August 2, 2006.

**THE TERMS OF THIS WARRANTY APPLY ONLY TO SALES MADE WHILE THIS WARRANTY IS IN EFFECT. THIS WARRANTY SHALL BE OF NO EFFECT IF AT THE TIME OF SALE A DIFFERENT WARRANTY IS POSTED ON THE COMPANY'S WEBSITE, [WWW.VICON-CCTV.COM](http://WWW.VICON-CCTV.COM). IN THAT EVENT, THE TERMS OF THE POSTED WARRANTY SHALL APPLY EXCLUSIVELY.**

Vicon Part Number: 8006-9010-03-02 Rev 806

## **Vicon Industries Inc.**

### **Corporate Headquarters**

89 Arkay Drive  
Hauppauge, New York 11788  
631-952-CCTV (2288) 800-645-9116  
Fax: 631-951-CCTV (2288)

### **Vicon Europe Headquarters**

Brunel Way  
Fareham, PO15 5TX  
United Kingdom  
+44 (0) 1489 566300  
Fax: +44 (0) 1489 566322

### **Germany**

vin-videotronic infosystems gmbh  
Lahnstrasse 1  
D-24539 Neumuenster  
Phone: +49 (0) 4321 8790  
Fax: +49 (0) 4321 879 47

### **Far East Office**

Unit 5, 17/F, Metropole Square  
2 On Yiu Street, Shatin  
New Territories,  
Hong Kong  
(852) 2145-7118  
Fax: (852) 2145-7117

**Internet Address: [www.vicon-cctv.com](http://www.vicon-cctv.com)**

